



- 11 - SPARE PARTS

11.1 WARNING FOR THE CUSTOMER

Before ordering any particular spare part, it is always necessary to specify the serial number of the machine to which the part shall fit.



11.2.1 LEGEND OF MACHINE'S BODY TP/TS1 (cod. 18.0000)



Pos.	Code	Description	Q.ty
1	180003	MAIN PLATE TP/TS1	1
1a	740151	SELF THREADING BUSHING M5 M8 X1 X7	4
1b	150513	PLASTIC ELBOW CONNECTOR KQL-06-01 S 90° 1/8 FOR AIR BOX	4
1c	950606	PIPE FITTING KQH-06-01 S	2
1d	900014	ALLEN CAP 1/8	8
2	150106	RUBBER FOOT D.18	4
2a	600050	SCREW TBEIM4X6	4
3	180007	CENTRAL PLATE HOLDER TP/TS1	1
3a	850218	PARALLEL PIN Ø5X20	2
4	900019	CAP SCREW M5X25	14
5	180010	SCREW TE M5X14	4
5a	600026	BLUED NUT M5	4
6	160004	SUPPORT FOR ADJUSTABLE DIE	1
6a	160015	SPINA CIL. D. 3X8	2
7	750314	CAP SCREW TCEIM5X15	4
8	180012	SCREW TSEITSEIM5X50	1
9	180103	KNOB	1
10	180002	SLIDING RING	2
11	180004	RIGHT AND LEFT SLIDING HOLDER	2
11a	740159	BUSHING MUBUX-M TYPE 970 M5/M7	8
12	750312	CAP SCREW M6X30	8
13	180005	BALL BEARING KBS22.12 L.32	8
14	500071	SCREW PCOM5X6 UK	8
15	750301	CS SCREW M5X12	4
16	180006	JOINT COUPLING FOR SLIDING HOLDER	2
17	180101	HOLDER FOR CUTTING BLADE AND RIGHT + LEFT PUNCH	2
17a	850417	PARALLEL PIN D.3X16	4
18	500055	CAP SCREW M5X15	4
19	340104	JOINT TP/LN-500	2
20	180001	RIGHT AND LEFT OUTER BODY SIDE	2
20a	850218	PARALLEL PIN Ø5X20	4
21	900018	CAP SCREW M6X45	4
22	950109	CAP SCREW M6X25	6
23	180009	CYLINDER ECQ2B63-20D SMC	2
23a	150501	PLASTIC ELBOW CONNECTOR KQL-06-01 S 90° 1/4	4
23b	150510	RILSAN HOSE D. 6X4 120 mm	4
24	180011	SCREW TCEIM8X60	8
25	150502	AIR REGULATOR EAR2000	1
25a	150503	PRESSURE GAUGE 0.10 MM FOR AIR REGULATOR.	1
25b	150504	BRACKET B 220 FOR REGULATOR EAR 2000	1
25c	150513	PLASTIC ELBOW CONNECTOR KQL-06-01 S 90° 1/8 FOR AIR BOX	1
25d	150501	PLASTIC ELBOW CONNECTOR KQL-06-01 S 90° 1/4	1



26	750106	SCREW TBEI M5X10 UNBRAKO	2
27	180102	CENTRAL SAFETY COVER FOR TP/TS1	1
27a	180105	THREADED NUT M5	3
27b	500070	SCREW TBEI M5X8	4
28	180008	RIGHT AND LEFT SAFETY COVER FOR TP/TS1	2
29	750302	BH SCREW M5X12	2
30	150509	PNEUMATIC PEDAL AM 50010B	1
30a	150512	SILENCER 2901 1/4 17 ON AIR EJECT	2
30b	150514	PLASTIC CONNECTOR KQH-06-02S 1/4	3
31	150521	POLYESTER SHEATH 20mm. L 1500mm	1
31a	150510	RILSAN HOSE D. 6X4	3
32	150510	RILSAN HOSE D. 6X4 L 1800 mm	1
ADJUSTMENT TOOLING			
A	400804	ALLEN KEY mm. 3	1
B	500062	KEY FOR FEEDER SE4	1

11.3 DETAILED DRAWINGS OF PREFORMING UNITS

11.3.1. DETAILED DRAWING OF DIE ASSEMBLY STAND OFF LOCK IN COD. 180600

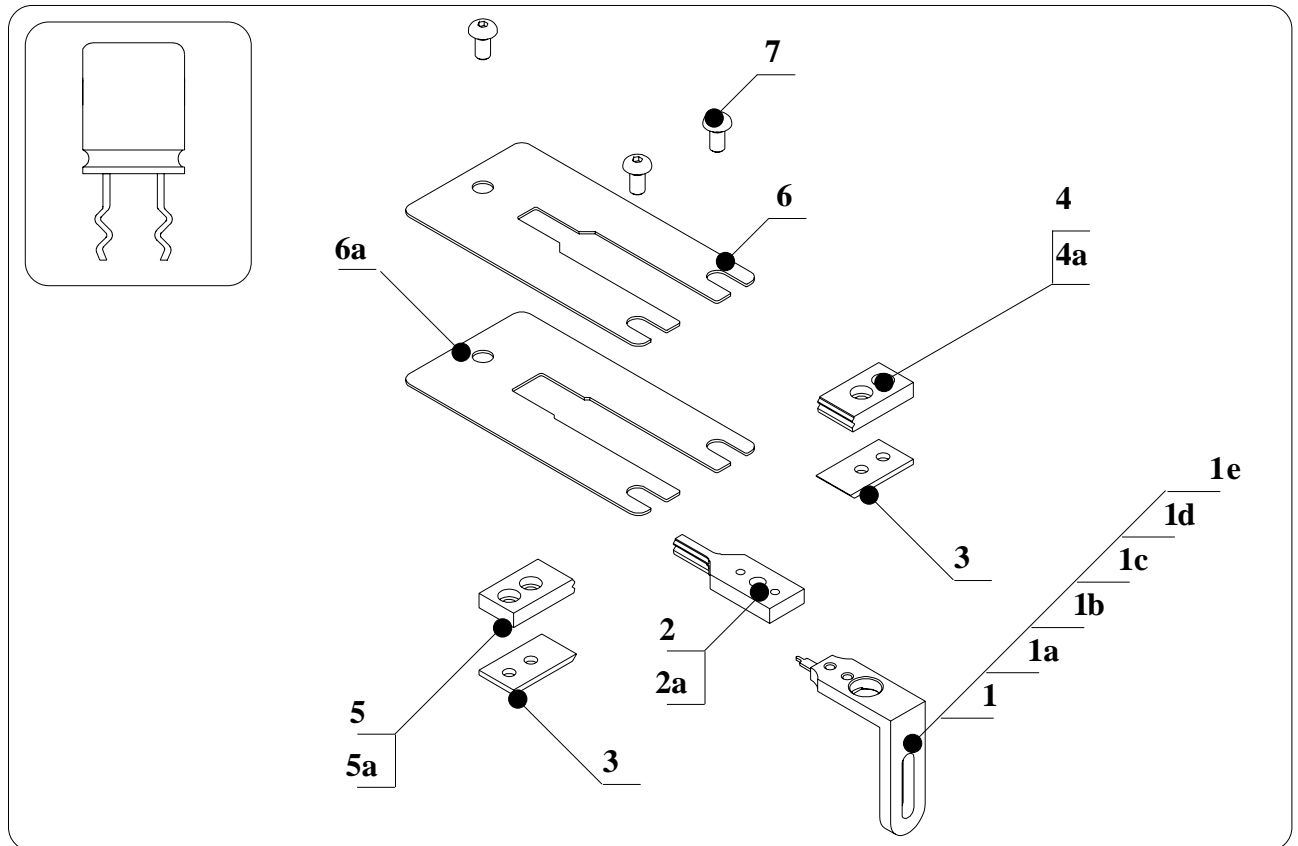

11.3.1.1 DETAILED SPARE PARTS LIST DIE ASSEMBLY STAND OFF LOCK IN COD. 180600

Pos.	Article	Description	Qty
1	180040	COMPLETE PREFORMING ADJUSTER FROM P=2 TO P=10,16	1
1a	160018	REFERENCE HOLDER FROM P=2 TO P=10,16	1
1b	160019	PREFORMING REFERENCE FROM P=2 TO P=10,16	1
1c	500006	CS SCREW M3X8	2
1d	780517	KNOB FC-M3	1
1e	160047	SCREW TS M3x10	1
2	160603	DIE P. 2,54 STAND OFF LOCK IN	1
2	160604	DIE P. 5,08 STAND OFF LOCK IN	1
2	160605	DIE P. 7,62 STAND OFF LOCK IN	1
2	160606	DIE P. 10,16 STAND OFF LOCK IN	1
2a	550012	BH SCREW M5X15	1
3	160607	CUTTING BLADES TP/SC4	2
4	160601	RIGHT PUNCH STAND OFF LOCK IN	1
4a	150210	REDUCED CAPSCREW M4X10	2
5	160602	LEFT PUNCH STAND OFF LOCK IN	1
5a	150210	REDUCED CAPSCREW M4X10	2
6	180106	SAFETY PROTECTION FOR PITCHES FROM 2 TO 5.08	1
6a	180107	SAFETY PROTECTION FOR PITCHES FROM 7.62 TO 10.16	1
7	500070	SCREW TBEI M5X8	3

11.3.2. DETAILED DRAWING OF DIE ASSEMBLY STAND OFF LOCK IN LED COD. 180700

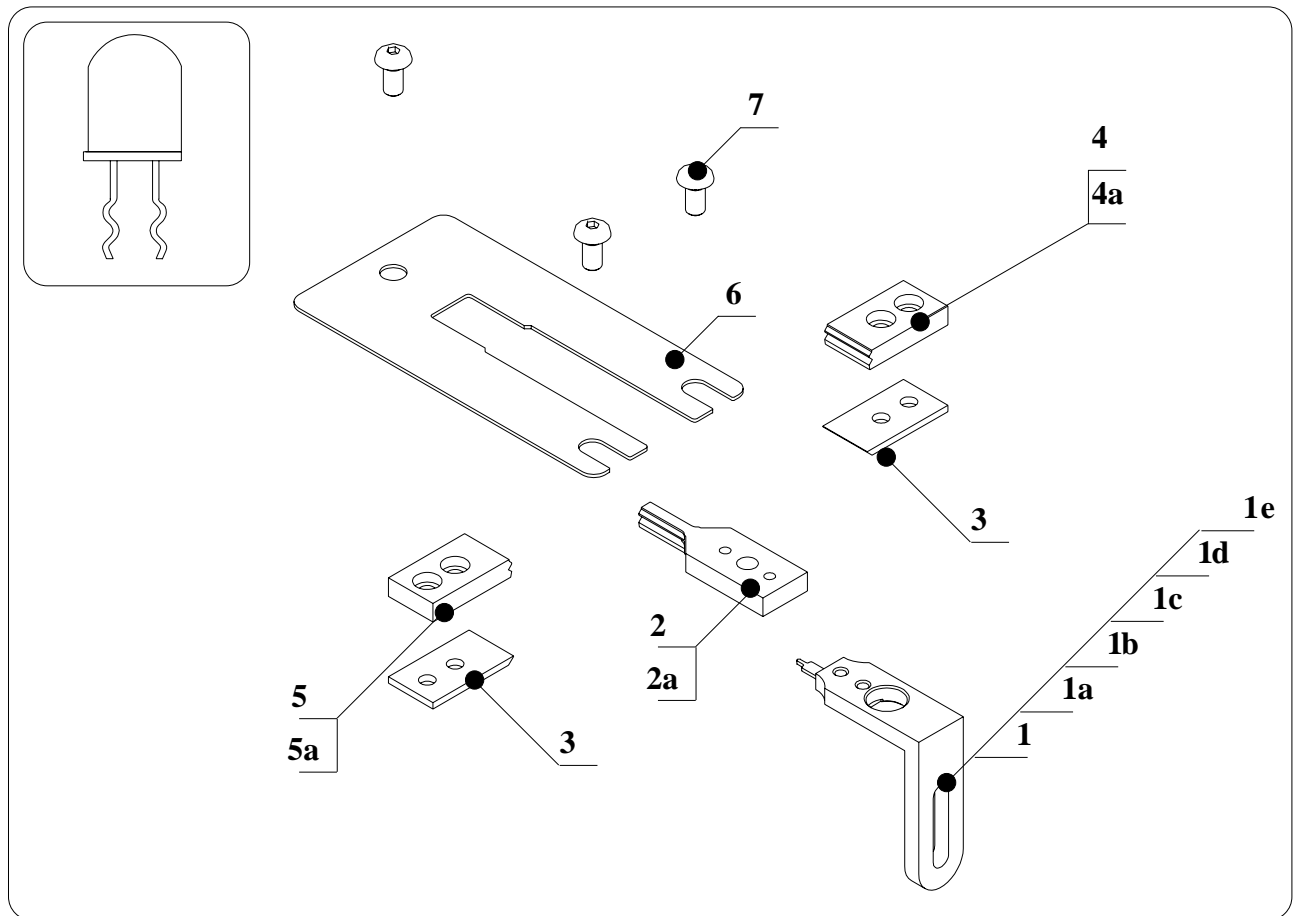

11.3.2.1 DETAILED SPARE PARTS LIST OF DIE ASSEMBLY STAND OFF LOCK IN LED COD. 180700

Pos.	Article	Description	Qty
1	180040	<u>COMPLETE PREFORMING ADJUSTER FROM P=2 TO P=10,16</u>	1
1a	160018	REFERENCE HOLDER FROM P=2 TO P=10,16	1
1b	160019	PREFORMING REFERENCE FROM P=2 TO P=10,16	1
1c	500006	CS SCREW M3X8	2
1d	780517	KNOB FC-M3	1
1e	160047	SCREW TS M3x10	1
2	160703	DIE P. 2MM STAND OFF LOCK IN	1
2a	550012	BH SCREW M5X15	1
3	160607	CUTTING BLADES TP/SC4	2
4	160701	RIGHT FORMING PUNCH P. 2MM STAND OFF LOCK IN-LED	1
4a	150210	REDUCED CAPSCREW M4X10	2
5	160702	LEFT FORMING PUNCH P. 2MM STAND OFF LOCK IN-LED	1
5a	150210	REDUCED CAPSCREW M4X10	2
6	180107	SAFETY PROTECTION FOR PITCHES FROM 7.62 TO 10.16	1
7	500070	SCREW TBEI M5X8	3

11.3.3. DETAILED DRAWING OF DIE ASSEMBLY STAND OFF - KINK OTWARDS COD. 180800

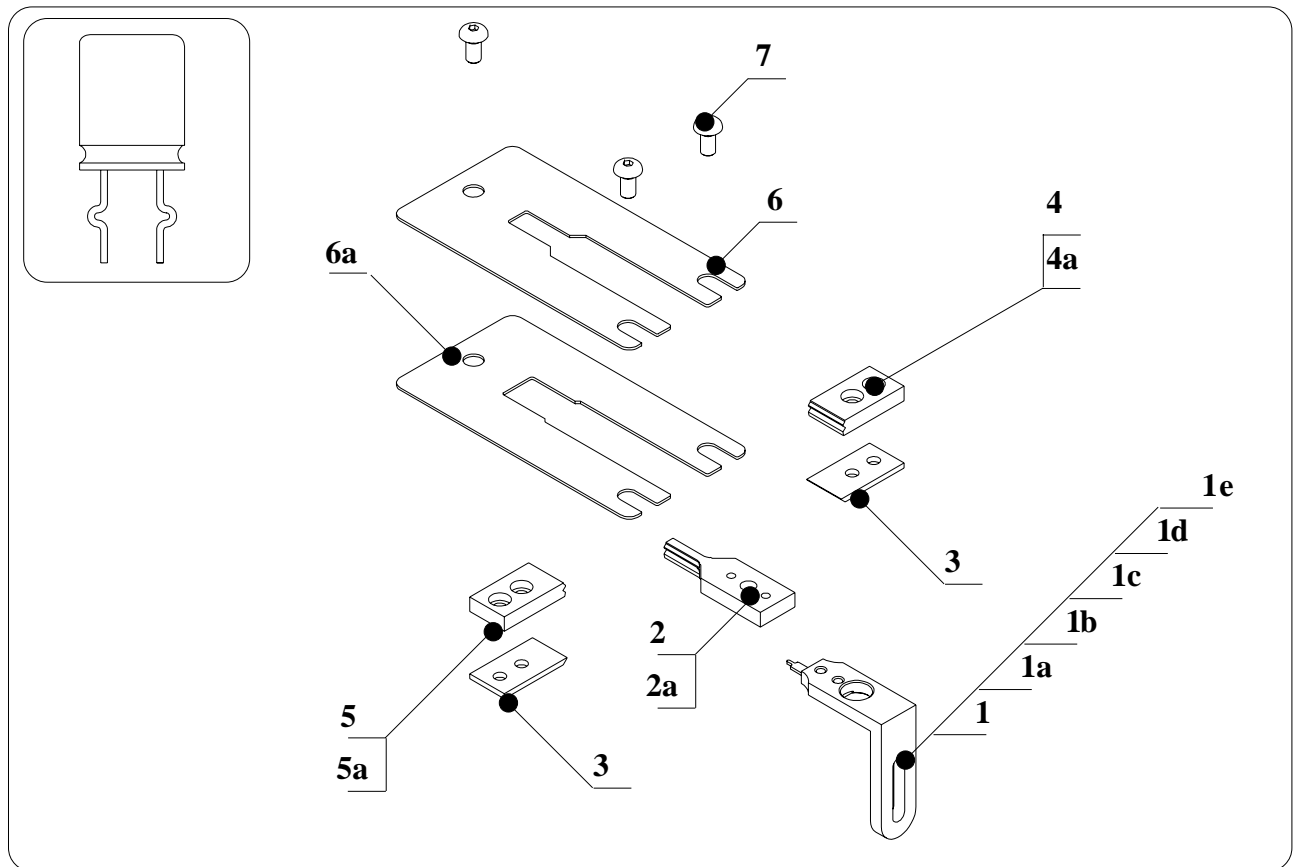

11.3.3.1 DETAILED SPARE PARTS LIST OF DIE ASSEMBLY STAND OFF - KINK OTWARD COD. 180800

Pos.	Article	Description	Qty
1	180040	COMPLETE PREFORMING ADJUSTER FROM P=2 TO P=10,16	1
1a	160018	REFERENCE HOLDER FROM P=2 TO P=10,16	1
1b	160019	PREFORMING REFERENCE FROM P=2 TO P=10,16	1
1c	500006	CS SCREW M3X8	2
1d	780517	KNOB FC-M3	1
1e	160047	SCREW TS M3x10	1
2	160803	DIE P. 2 STAND OFF KINK OUTWARDS	1
2	160804	DIE P. 2,54 STAND OFF KINK OUTWARDS	1
2	160805	DIE P. 5,08 STAND OFF KINK OUTWARDS	1
2	160806	DIE P. 7,62 STAND OFF KINK OUTWARDS	1
2	160807	DIE P. 10,16 STAND OFF KINK OUTWARDS	1
2a	550012	BH SCREW M5X15	1
3	160607	CUTTING BLADES TP/SC4	2
4	160801	RIGHT FORMING PUNCH STANDOFF KINK OUTWARDS	1
4a	150210	REDUCED CAPSCREW M4X10	2
5	160802	LEFT FORMING PUNCH STANDOFF KINK OUTWARDS	1
6a	150210	REDUCED CAPSCREW M4X10	2
6	180106	SAFETY PROTECTION FOR PITCHES FROM 2 TO 5.08	1
6a	180107	SAFETY PROTECTION FOR PITCHES FROM 7.62 TO 10.16	1
7	500070	SCREW TBEI M5X8	3

11.3.4. DETAILED DRAWING OF DIE ASSEMBLY BODY LOCKED ON PCB COD. 180900

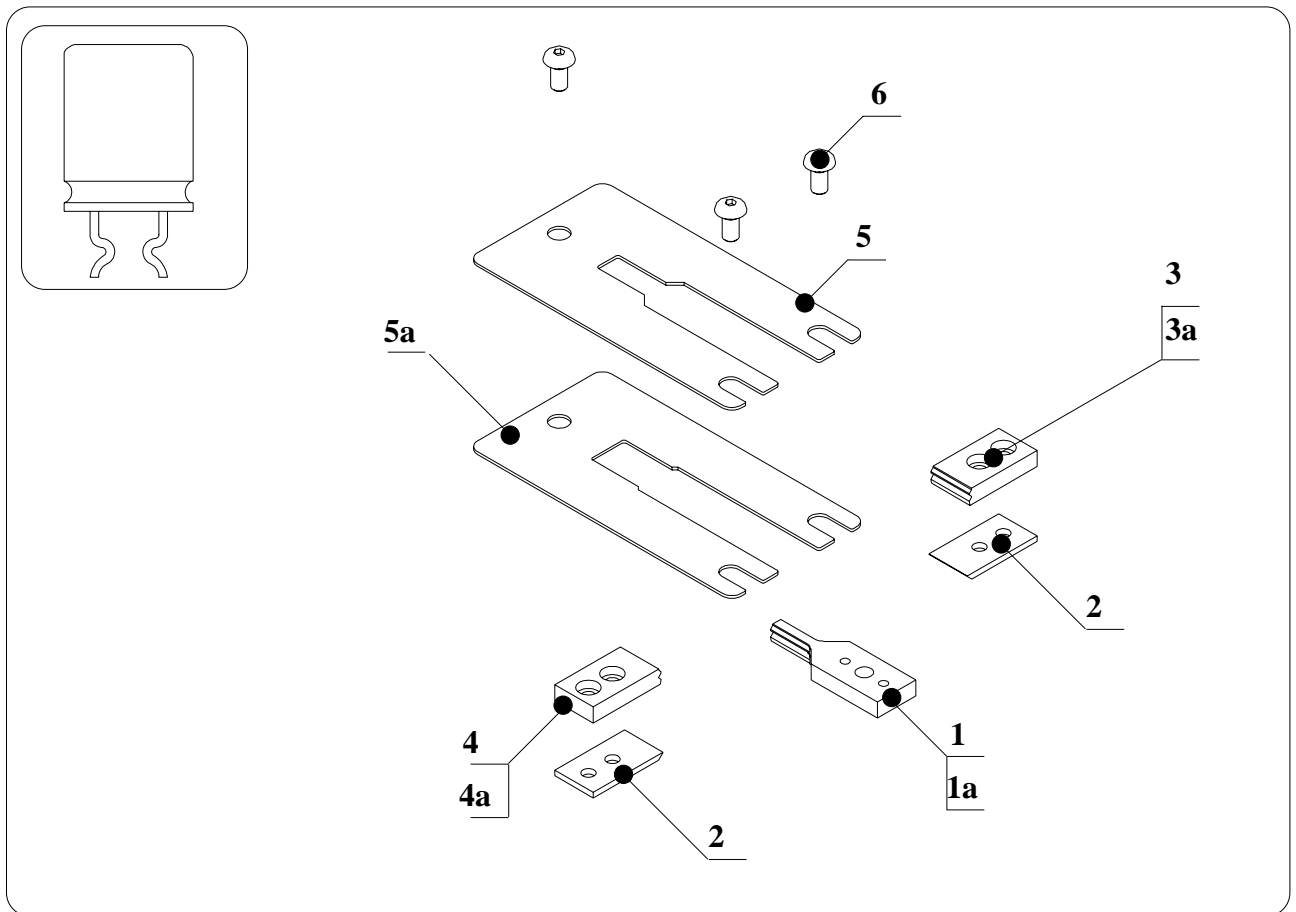

11.3.4.1 DETAILED SPARE PARTS LIST OF DIE ASSEMBLY BODY LOCKED ON PCB COD. 180900

Pos.	Article	Description	Qty
1	160903	DIE P. 2,54 BODY LOCKED ON PCB	1
1	160904	DIE P. 5,08 BODY LOCKED ON PCB	1
1	160905	DIE P. 7,62 BODY LOCKED ON PCB	1
1	160906	DIE P. 10,16 BODY LOCKED ON PCB	1
1a	750302	BH SCREW M5X12	1
2	160607	CUTTING BLADES TP/SC4	2
3	160901	RIGHT FORMING PUNCH BODY LOCKED ON P.C.B.	1
3a	150210	REDUCED CAPSCREW M4X10	2
4	160902	LEFT FORMING PUNCH BODY LOCKED ON P.C.B.	1
4a	150210	REDUCED CAPSCREW M4X10	2
6	180106	SAFETY PROTECTION FOR PITCHES FROM 2 TO 5.08	1
6a	180107	SAFETY PROTECTION FOR PITCHES FROM 7.62 TO 10.16	1
7	500070	SCREW TBEI M5X8	3

11.3.5. DETAILED DRAWING OF DIE ASSEMBLY STRAIGHT CUT COD. 181000

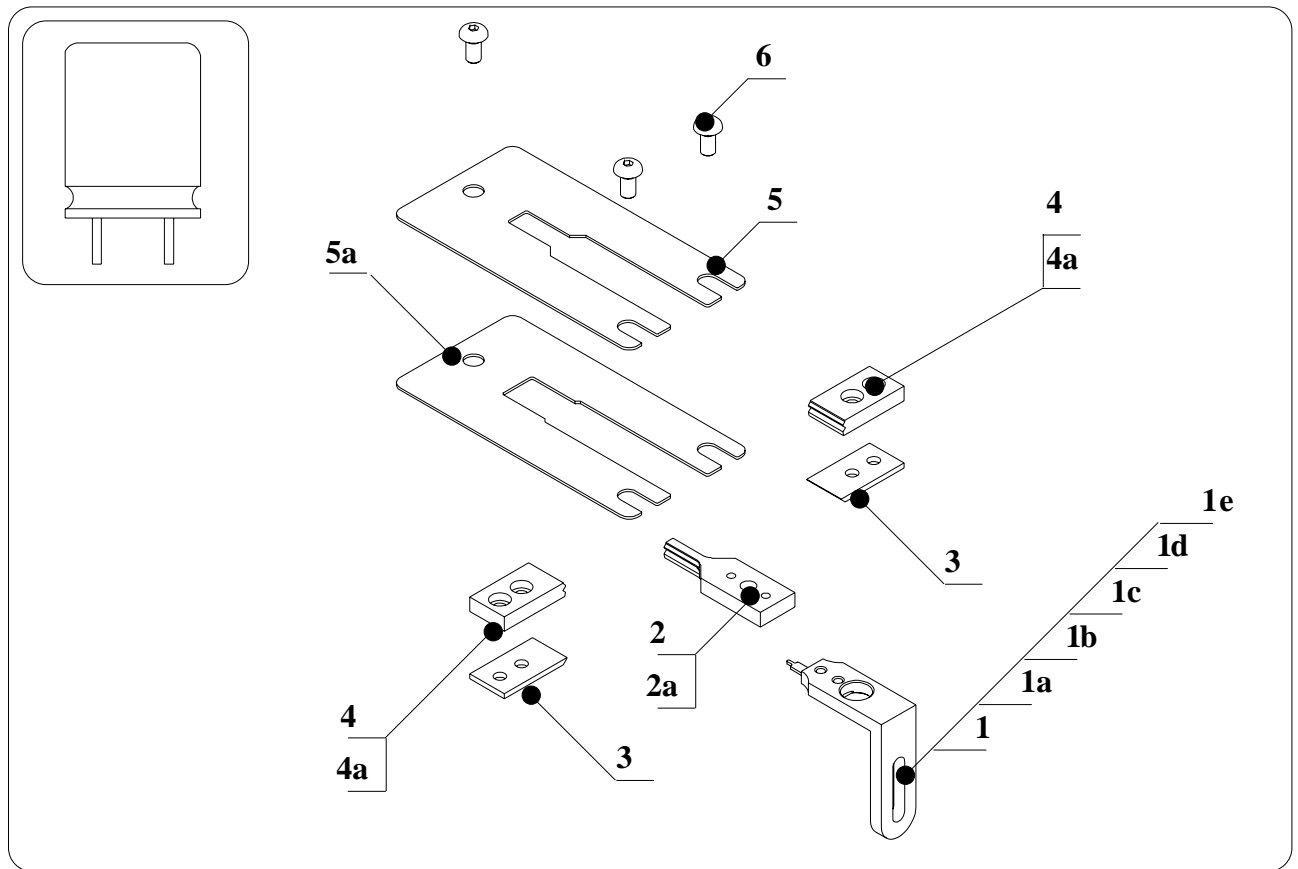

11.3.5.1 DETAILED SPARE PARTS LIST OF DIE ASSEMBLY STRAIGHT CUT COD. 181000

Ref.	Item	Description	Qty
1	180040	<u>COMPLETE PREFORMING ADJUSTER FROM P=2 TO P=10,16</u>	1
1a	160018	REFERENCE HOLDER FROM P=2 TO P=10,16	1
1b	160019	PREFORMING REFERENCE FROM P=2 TO P=10,16	1
1c	500006	CS SCREW M3X8	2
1d	780517	KNOB FC-M3	1
1e	160047	SCREW TS M3x10	1
2	161002	DIE P. 2,54 STRAIGHT CUT	1
2	161003	DIE P. 5,08 STRAIGHT CUT	1
2	161004	DIE P. 7,62 STRAIGHT CUT	1
2	161005	DIE P. 10,16 STRAIGHT CUT	1
2a	750302	BH SCREW M5X12	1
3	160607	CUTTING BLADES TP/SC4	2
4	161001	SIDE PUNCH STRAIGHT CUT	2
4a	150210	REDUCED CAPSCREW M4X10	4
6	180106	SAFETY PROTECTION FOR PITCHES FROM 2 TO 5.08	1
6a	180107	SAFETY PROTECTION FOR PITCHES FROM 7.62 TO 10.16	1
7	500070	SCREW TBEI M5X8	3

11.3.6. DETAILED DRAWING OF PREFORMING UNIT COD. 181100 four leads diode bridge

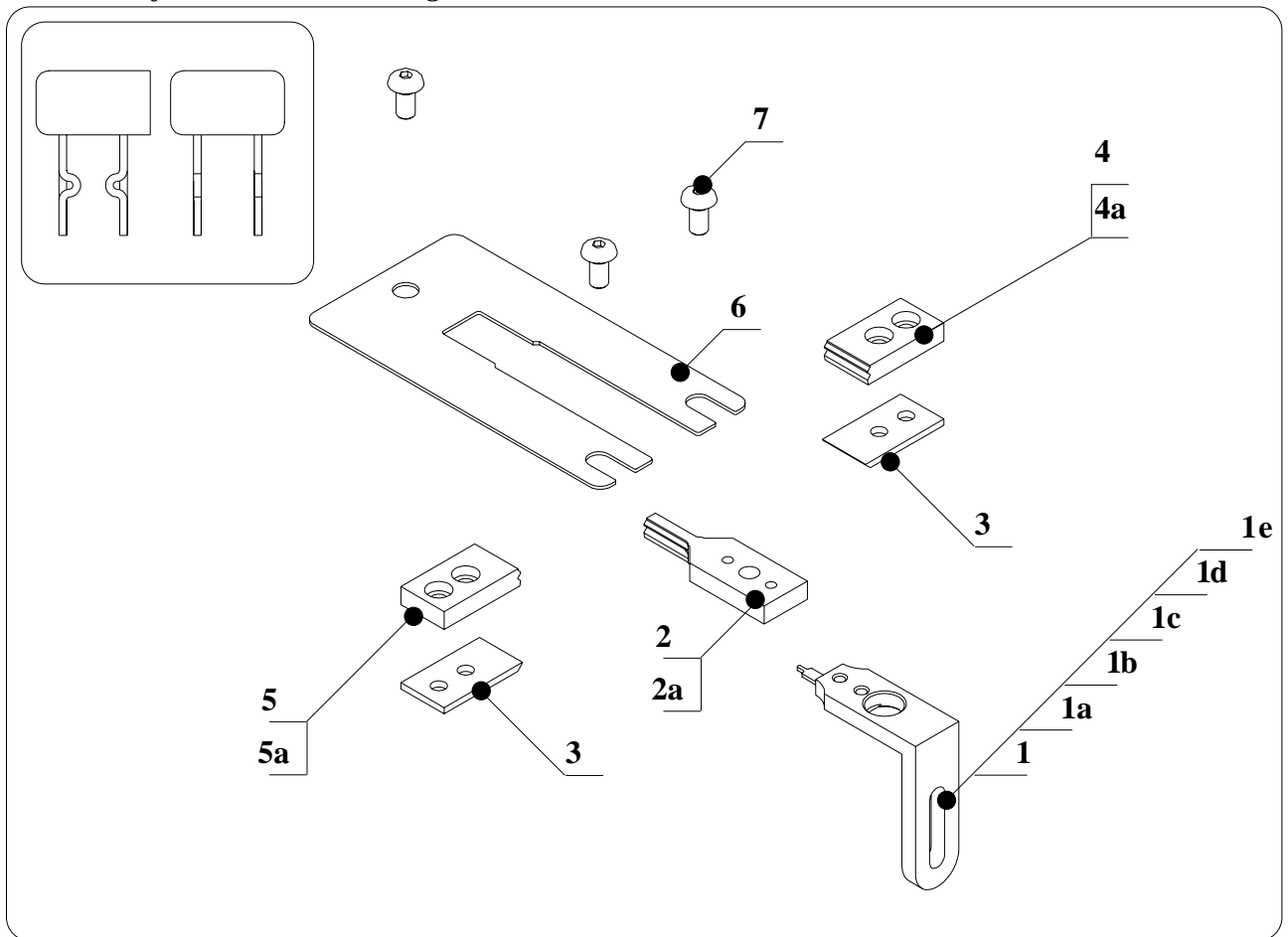

11.3.6.1 DETAILED SPARE PARTS LIST OF PREFORMING UNIT COD. 181100

Ref.	Item	Description	Qty
1	180040	COMPLETE PREFORMING ADJUSTER FROM P=2 TO P=10,16	1
1a	160018	REFERENCE HOLDER FROM P=2 TO P=10,16	1
1b	160019	PREFORMING REFERENCE FROM P=2 TO P=10,16	1
1c	500006	CS SCREW M3X8	2
1d	780517	KNOB FC-M3	1
1e	160047	SCREW TS M3x10	1
2	161101	DIE DIODE BRIDGE 4 LEADS P=5,08	1
2a	550012	BH SCREW M5X15	1
3	160607	CUTTING BLADE TP/SC4	2
4	161510	RIGHT FORMING PUNCH STAND OFF KINK INWARDS P. 2-2,54	1
4a	150210	REDUCED CAPSCREW M4X10	2
5	161511	LEFT FORMING PUNCH STAND OFF KINK INWARDS P. 2-2,54	1
5a	150210	REDUCED CAPSCREW M4X10	2
6	180107	SAFETY PROTECTION FOR PITCHES FROM 7.62 TO 10.16	1
7	500070	SCREW TBEI M5X8	3

11.3.7. DETAILED DRAWING OF PREFORMING UNIT COD. 181200 POLARITY

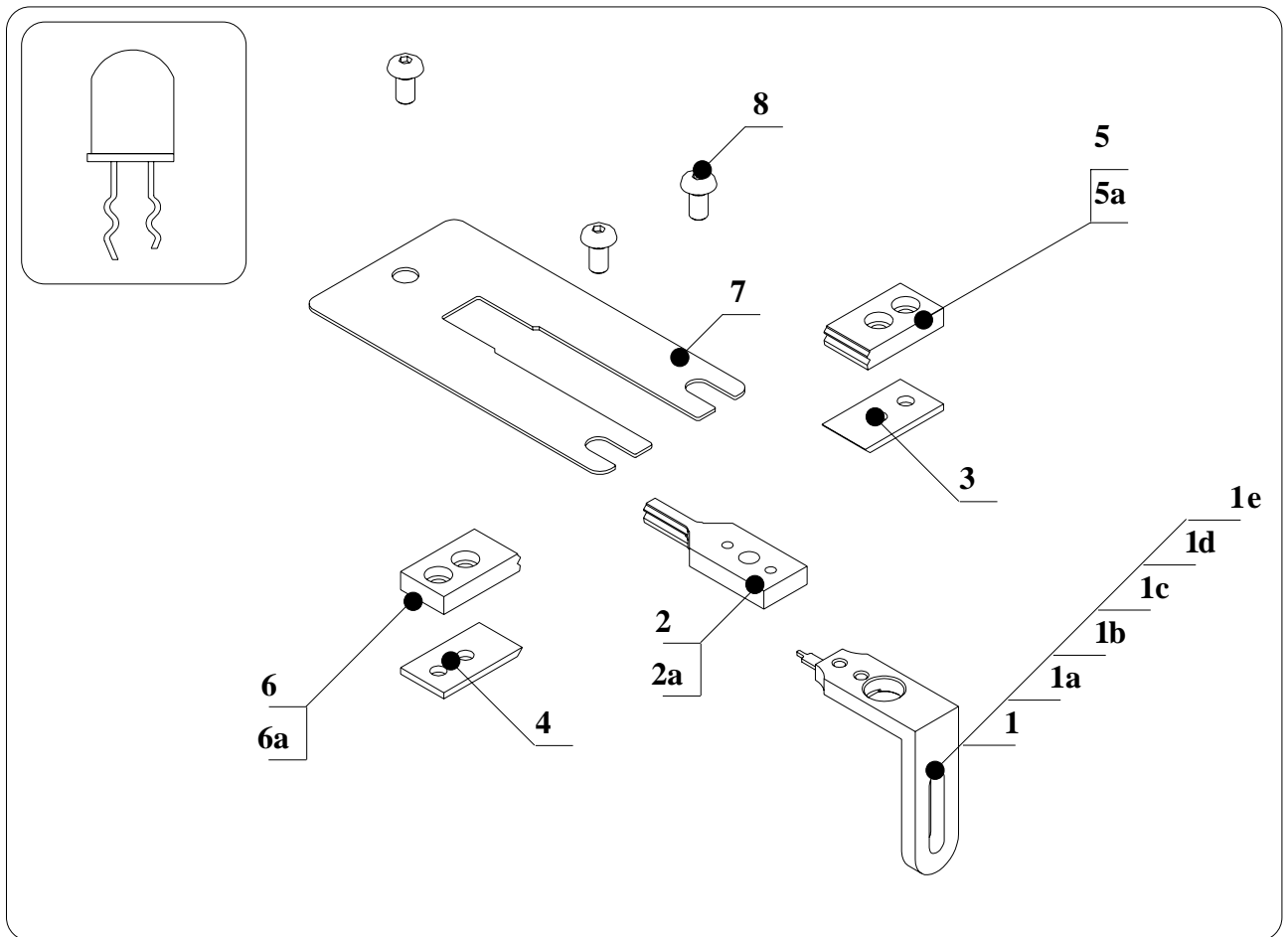

11.3.7.1 DETAILED SPARE PARTS LIST OF PREFORMING UNIT COD. 181200

Ref.	Item	Description	Qty
1	180040	COMPLETE PREFORMING ADJUSTER FROM P=2 TO P=10,16	1
1a	160018	REFERENCE HOLDER FROM P=2 TO P=10,16	1
1b	160019	PREFORMING REFERENCE FROM P=2 TO P=10,16	1
1c	500006	CS SCREW M3X8	2
1d	780517	KNOB FC-M3	1
1e	160047	SCREW TS M3x10	1
2	161205	DIE P. 2,54 POLARITY	1
2a	550012	BH SCREW M5X15	1
3	160607	CUTTING BLADE TP/SC4	1
4	161202	LEFT CUTTING BLADE POLARITY	1
5	161201	RIGHT FORMING PUNCH POLARITY	1
5a	150210	REDUCED CAPSCREW M4X10	2
6	161203	LEFT FORMING PUNCH POLARITY	1
6a	150210	REDUCED CAPSCREW M4X10	2
7	180107	SAFETY PROTECTION FOR PITCHES FROM 7.62 TO 10.16	1
8	500070	SCREW TBEI M5X8	3

11.3.8. DETAILED DRAWING OF PREFORMING UNIT COD. 181300 90° BENDING

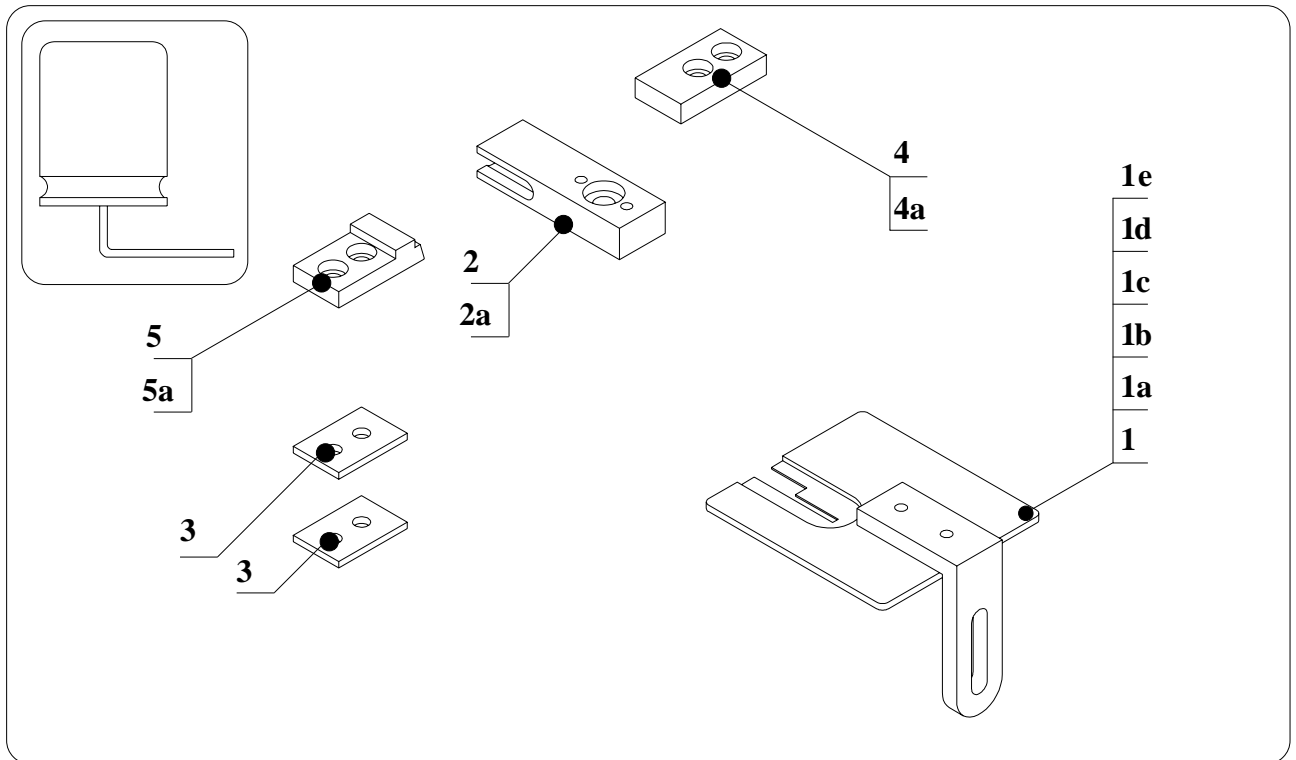

11.3.8.1 DETAILED SPARE PARTS LIST OF PREFORMING UNIT COD. 181300

Ref.	Item	Description	Q.ty
1	180041	COMPLETE PREFORMING ADJUSTERS SMD COMPONENTS AND 90° BENDING	1
1a	160021	REFERENCE HOLDER FOR SMD / 90° BENDING/ TO220	1
1b	160022	PREFORMING REFERENCE FOR SMD AND 90° BENDING	1
1c	160047	SCREW TS M3x10	2
1d	400116	NUT M3	1
1e	780517	KNOB FC-M3	1
2	161301	DIE 90° BENDING	1
2a	550012	BH SCREW M5X15	1
3	160016	THICKNESS PLATE	2
4	161403	RIGHT FORMING PUNCH	1
4a	150210	REDUCED CAPSCREW M4X10	2
5	161302	CUTTING FORMING PUNCH 90° BENDING	1
5a	150210	REDUCED CAPSCREW M4X10	2

11.3.9. DETAILED DRAWING OF PREFORMING UNIT COD. 181400 SURFACE MOUNTING

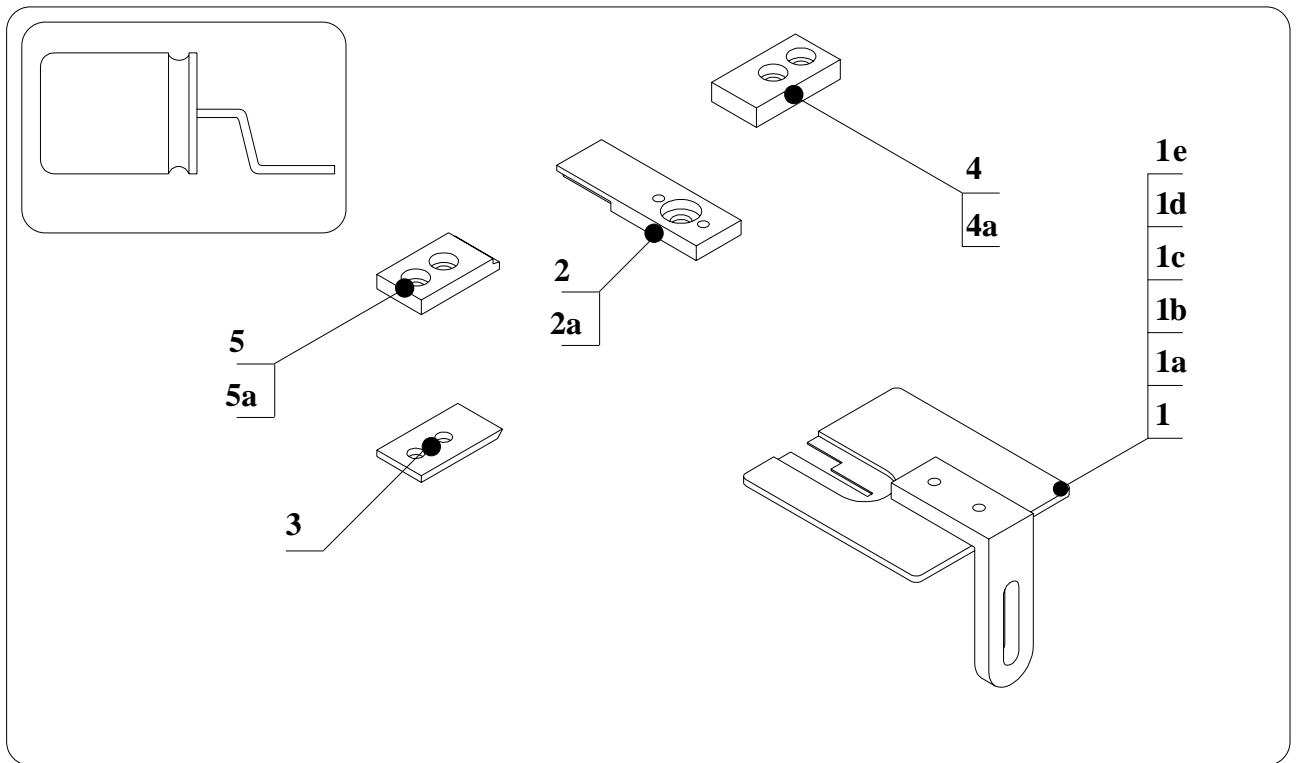

11.3.9.1 DETAILES SPARE PARTS LIST OF PREFORMING UNIT COD. 181400

Ref.	Item	Description	Q.ty
1	180041	COMPLETE PREFORMING ADJUSTERSMD COMPONENTS AND 90° BENDING	1
1a	160021	REFERENCE HOLDER FOR SMD / 90° BENDING/ TO220	1
1b	160022	PREFORMING REFERENCE FOR SMD AND 90° BENDING	1
1c	160047	SCREW TS M3x10	2
1d	400116	NUT M3	1
1e	780517	KNOB FC-M3	1
2	161402	DIE SURFACE MOUNTING	1
2a	750302	BH SCREW M5X12	1
3	160607	CUTTING BLADE TP/SC4	2
4	161403	RIGHT FORMING PUNCH	1
4a	150210	REDUCED CAPSCREW M4X10	2
5	161401	LEFT FORMING PUNCH SURFACE MOUNTING	1
5a	150210	REDUCED CAPSCREW M4X10	2

**11.3.10. DETAILED DRAWING OF PREFORMING UNIT COD. 181500
STAND OFF - KINK INWARDS**

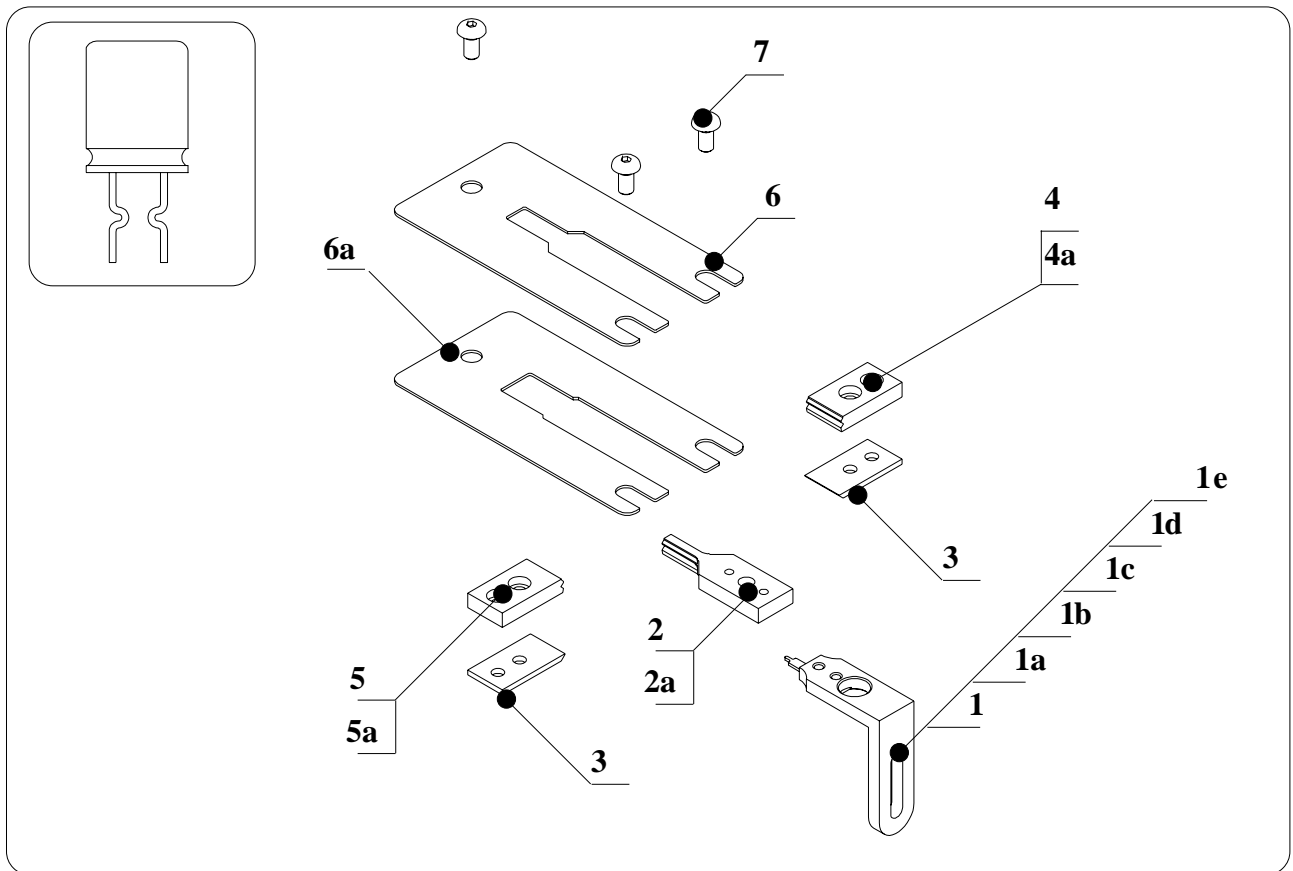

11.3.10.1 DETAILED SPARE PARTS LIST OF PREFORMING UNIT COD. 181500

Ref.	Item	Description	Qty
1	180040	COMPLETE PREFORMING ADJUSTER FROM P=2 TO P=10,16	1
1a	160018	REFERENCE HOLDER FROM P=2 TO P=10,16	1
1b	160019	PREFORMING REFERENCE FROM P=2 TO P=10,16	1
1c	500006	CS SCREW M3X8	2
1d	780517	KNOB FC-M3	1
1e	160047	SCREW TS M3x10	1
2	161503	DIE P. 2,54 STAND OFF KINK INWARDS	1
2	161505	DIE P. 5,08 STAND OFF KINK INWARDS	1
2	161506	DIE P. 7,62 STAND OFF KINK INWARDS	1
2	161507	DIE P. 10,16 STAND OFF KINK INWARDS	1
2a	550012	BH SCREW M5X15	1
3	160607	CUTTING BLADE TP/SC4	2
4	161510	RIGHT FORMING PUNCH STAND OFF KINK INWARDS P. 2-2,54	1
4	161508	RIGHT FORMING PUNCH STAND OFF KINK INWARDS 5,08-10,16	1
4a	150210	REDUCED CAPSCREW M4X10	2
5	161511	LEFT FORMING PUNCH STAND OFF KINK INWARDS P. 2-2,54	1
5	161509	LEFT FORMING PUNCH STAND OFF KINK INWARDS 5,08-10,16	1
5a	150210	REDUCED CAPSCREW M4X10	2
6	180106	SAFETY PROTECTION FOR PITCHES FROM 2 TO 5.08	1
6a	180107	SAFETY PROTECTION FOR PITCHES FROM 7.62 TO 10.16	1
7	500070	SCREW TBEI M5X8	3

11.3.11. DETAILED DRAWING OF PREFORMING UNIT COD. 181700 TO SPREAD OUT AND CUT

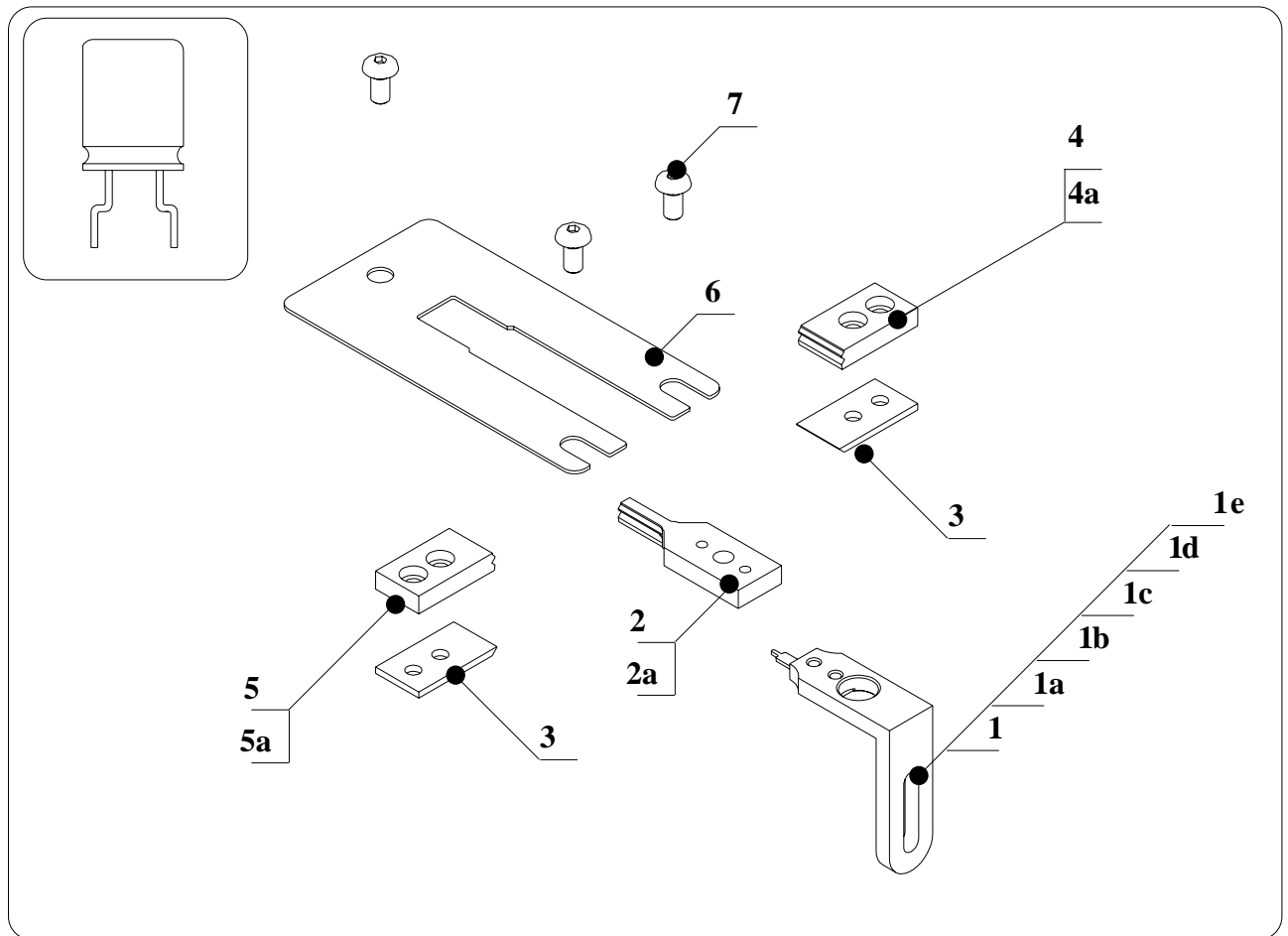

11.3.11.1 DETAILED SPARE PARTS LIST OF PREFORMING UNIT COD. 181700

Ref.	Item	Description	Q.ty
1	180040	COMPLETE PREFORMING ADJUSTER FROM P=2 TO P=10,16	1
1a	160018	REFERENCE HOLDER FROM P=2 TO P=10,16	1
1b	160019	PREFORMING REFERENCE FROM P=2 TO P=10,16	1
1c	500006	CS SCREW M3X8	2
1d	780517	KNOB FC-M3	1
1e	160047	SCREW TS M3x10	1
2	161703	DIE TO SPREAD OUT AND CUT	1
2a	550012	BH SCREW M5X15	1
3	160607	CUTTING BLADE TP/SC4	2
4	161701	RIGHT FORMING PUNCH TO SPREAD OUT AND CUT	1
4a	150210	REDUCED CAPSCREW M4X10	2
5	161702	LEFT FORMING PUNCH TO SPREAD OUT AND CUT	1
5a	150210	REDUCED CAPSCREW M4X10	2
6	180107	SAFETY PROTECTION FOR PITCHES FROM 7.62 TO 10.16	1
7	500070	SCREW TBEI M5X8	3

**11.3.12. DETAILED DRAWING OF PREFORMING UNIT COD. 181800
TO REDUCE PITCH AND CUT**

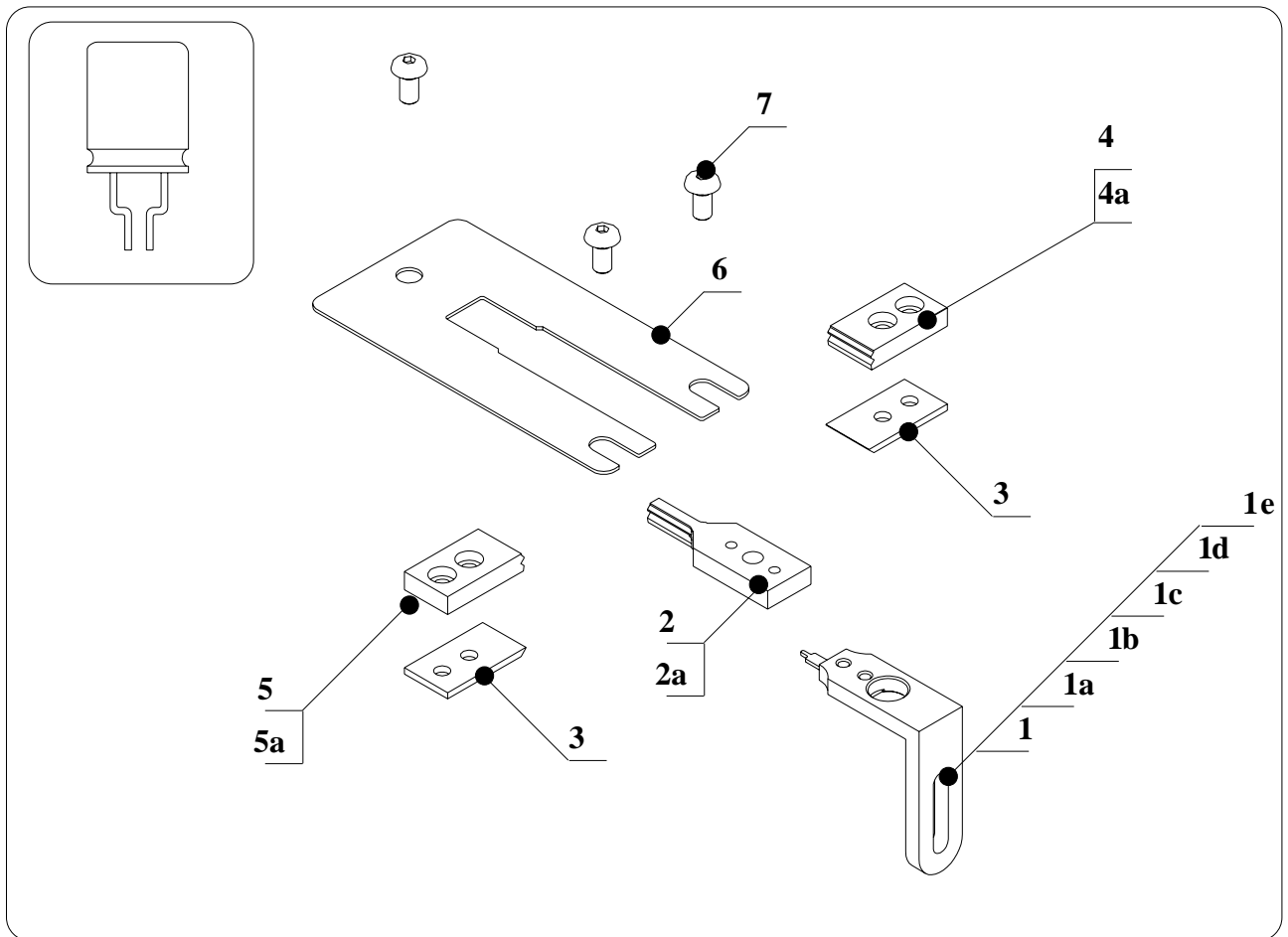

11.3.12.1 DETAILED SPARE PARTS LIST OF PREFORMING UNIT COD. 181800

Ref.	Item	Description	Qty
1	180040	COMPLETE PREFORMING ADJUSTER FROM P=2 TO P=10,16	1
1a	160018	REFERENCE HOLDER FROM P=2 TO P=10,16	1
1b	160019	PREFORMING REFERENCE FROM P=2 TO P=10,16	1
1c	500006	CS SCREW M3X8	2
1d	780517	KNOB FC-M3	1
1e	160047	SCREW TS M3x10	1
2	161803	DIE TO REDUCE PITCH AND CUT	1
2a	550012	BH SCREW M5X15	1
3	160607	CUTTING BLADE TP/SC4	2
4	161801	RIGHT FORMING PUNCH TO REDUCE PITCH AND CUT	1
4a	150210	REDUCED CAPSCREW M4X10	2
5	161802	LEFT FORMING PUNCH TO REDUCE PITCH AND CUT	1
5a	150210	REDUCED CAPSCREW M4X10	2
6	180107	SAFETY PROTECTION FOR PITCHES FROM 7.62 TO 10.16	1
7	500070	SCREW TBEI M5X8	3

11.3.13. DETAILED DRAWING OF PREFORMING UNIT COD. 182100 TO 220 CENTER LEAD SPREAD & CUT

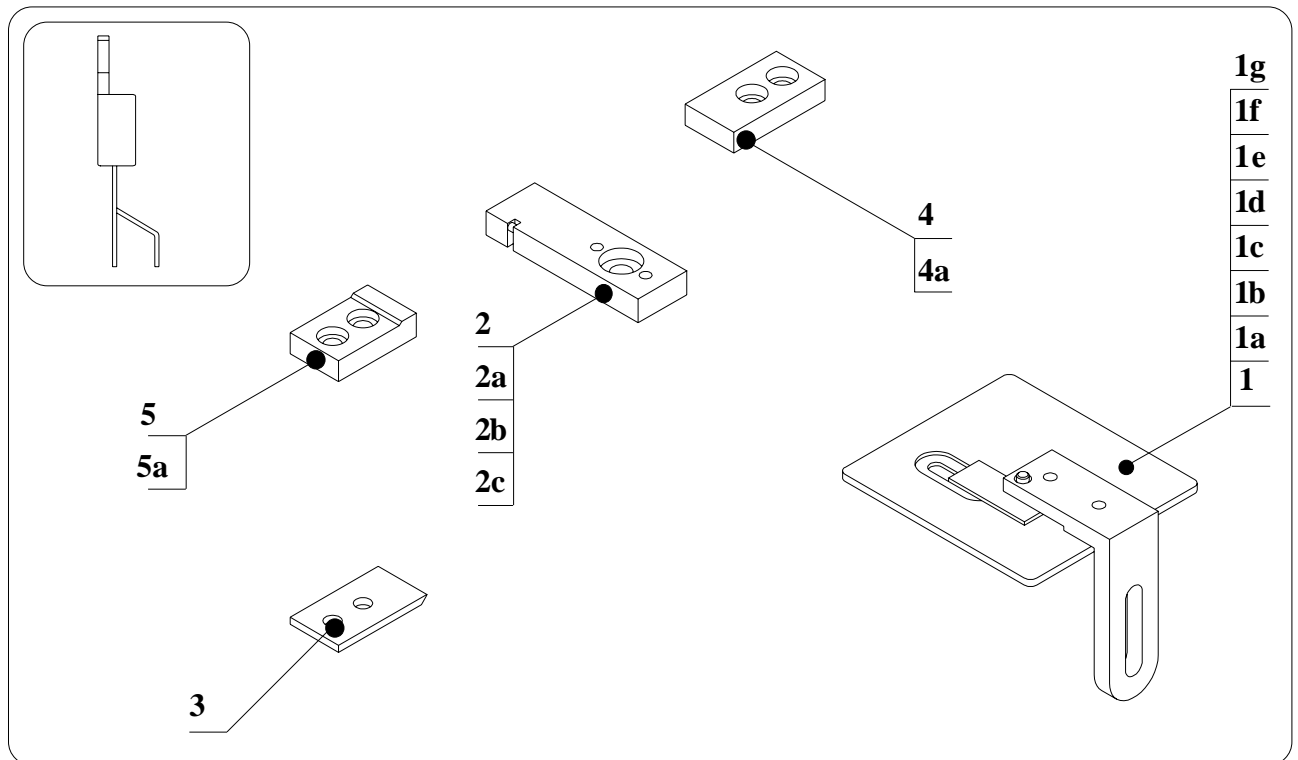

11.3.13.1 DETAILED SPARE PARTS LIST OF PREFORMING UNIT COD. 182100

Ref.	Item	Description	Qty
1	180042	COMPLETE HEIGHT ADJUSTER FOR COMP. TO220	1
1a	160024	HEIGHT ADJUSTER HOLDER FOR TO220 AND 90° BENDING CENT. LEAD SPREAD	1
1b	160031	PLATE	1
1c	850415	SCREW PP M3X4	1
1d	160025	PREFORMING REFERENCE FOR TO220	1
1e	160047	SCREW TS M3x10	2
1f	400116	NUT M3	1
1g	780517	KNOB FC-M3	1
2	162101	DIETO220 CENTER LEAD SPREAD ON AND CUT	1
2a	550012	BH SCREW M5X15	1
2b	152110	CYLINDRIC PIN D. 2x10	1
2c	750302	BH SCREW M5X12	1
3	160607	CUTTING BLADE TP/SC4	1
4	161403	RIGHT FORMING PUNCH	1
4a	150210	REDUCED CAPSCREW M4X10	1
5	162102	LEFT FORMING PUNCH TO220 CENT.LEAD SPREAD ON & CUT	1
5a	150210	REDUCED CAPSCREW M4X10	1

**11.3.14. DETAILED DRAWING OF PREFORMING UNIT COD. 183100
TO 220 90° BENDING CENTER LEAD OFF SET**

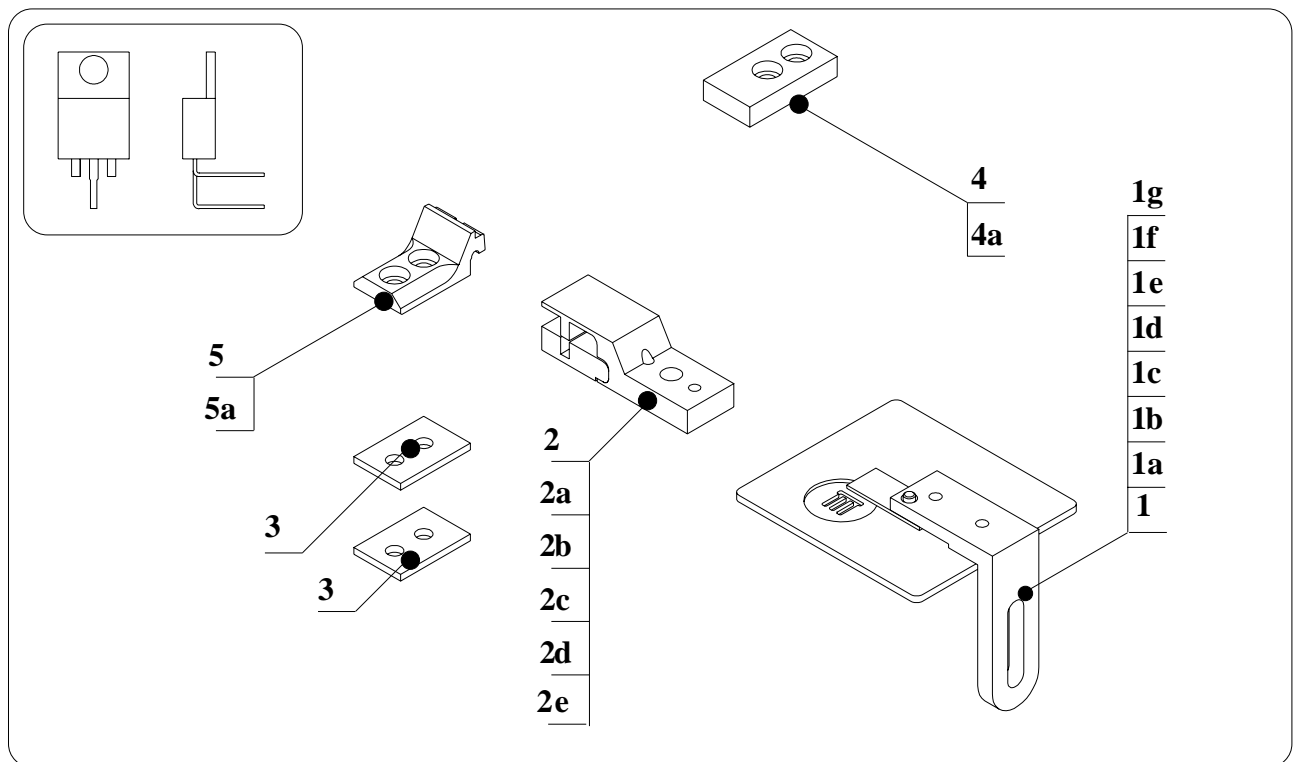

11.3.14.1 DETAILED SPARE PARTS LIST OF PREFORMING UNIT COD. 183100

Ref.	Item	Description	Q.ty
1	180043	<u>HEIGHT ADJUSTER COMP. 90° BENDING CENTER LEAD OFF SET</u>	1
1a	160024	HEIGHT ADJUSTER HOLDER FOR TO220 AND 90° BENDING CENT. LEAD SPREAD	1
1b	160031	PLATE	1
1c	850415	SCREW PP M3X4	1
1d	160027	PREFORMING REFERENCE FOR 90° BENDING CENTER LEAD OFF SET	1
1e	160047	SCREW TS M3x10	2
1f	400116	NUT M3	1
1g	780517	KNOB FC-M3	1
2	163101	<u>COMPLETE DIE TO220 90° BENDING CENTER LEAD OFF SET</u>	1
2a	162110	DIE 90° BENDING DIFFERENCED	1
2b	152110	CYLINDRIC PIN D. 2x10	1
2c	162111	SMALL BLOCK FOR DIE TO220	1
2d	160047	SCREW TS M3x10	2
2e	550012	BH SCREW M5X15	1
3	160016	THICKNESS PLATE	2
4	161403	RIGHT FORMING PUNCH	1
4a	150210	REDUCED CAPSCREW M4X10	2
5	163102	LEFT PUNCH TO220 90° BENDING CENTER LEAD OFF SET	1
5a	150210	REDUCED CAPSCREW M4X10	2

**11.3.15. DETAILED DRAWING OF PREFORMING UNIT COD. 182200
TO 220 CENTER LEAD SPREAD & LOCK**

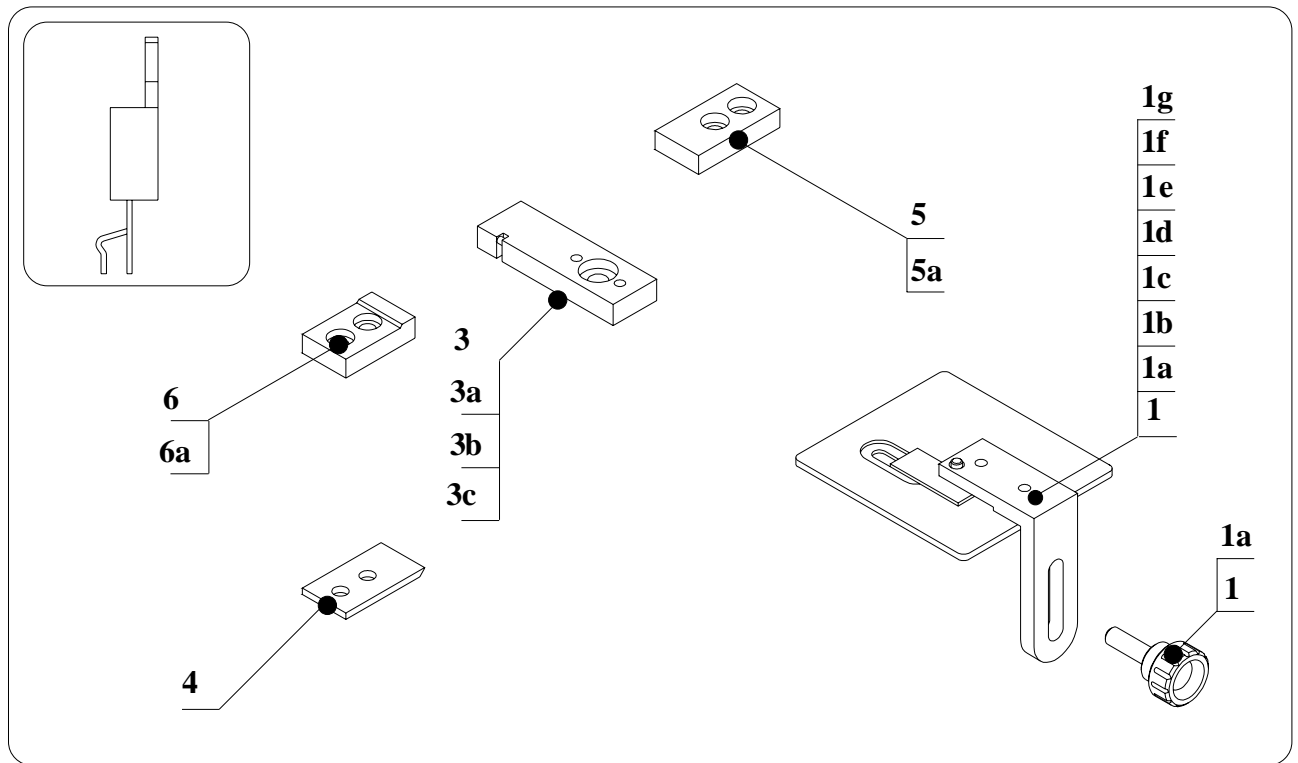

11.3.15.1 DETAILED SPARE PARTS LIST OF PREFORMING UNIT COD. 182200

Ref.	Item	Description	Qty
1	180042	COMPLETE HEIGHT ADJUSTER FOR COMP. TO220	1
1a	160024	HEIGHT ADJUSTER HOLDER FOR TO220 AND 90° BENDING CENT. LEAD SPREAD	1
1b	160031	PLATE	1
1c	850415	SCREW PP M3X4	1
1d	160025	PREFORMING REFERENCE FOR TO220	1
1e	160047	SCREW TS M3x10	2
1f	400116	NUT M3	1
1g	780517	KNOB FC-M3	1
2	162201	COMPLETE DIE TO220 CENTER LEAD SPREAD & LOCK	1
2a	162203	DIE TO220 CENTER LEAD SPREAD & LOCK	1
2b	152110	CYLINDRIC PIN D. 2x10	1
2c	750302	BH SCREW M5X12	1
3	160607	CUTTING BLADE TP/SC4	1
4	161403	RIGHT FORMING PUNCH	1
4a	150210	REDUCED CAPSCREW M4X10	2
5	162202	LEFT FORMIGN PUNCH TO220 CENT.LEAD SPREAD & LOCK	1
5a	150210	REDUCED CAPSCREW M4X10	2

**11.3.16. DETAILED DRAWING OF PREFORMING UNIT COD. 182300
TO 220 CENTER LEAD SPREAD & 3 LEAD LOCK**

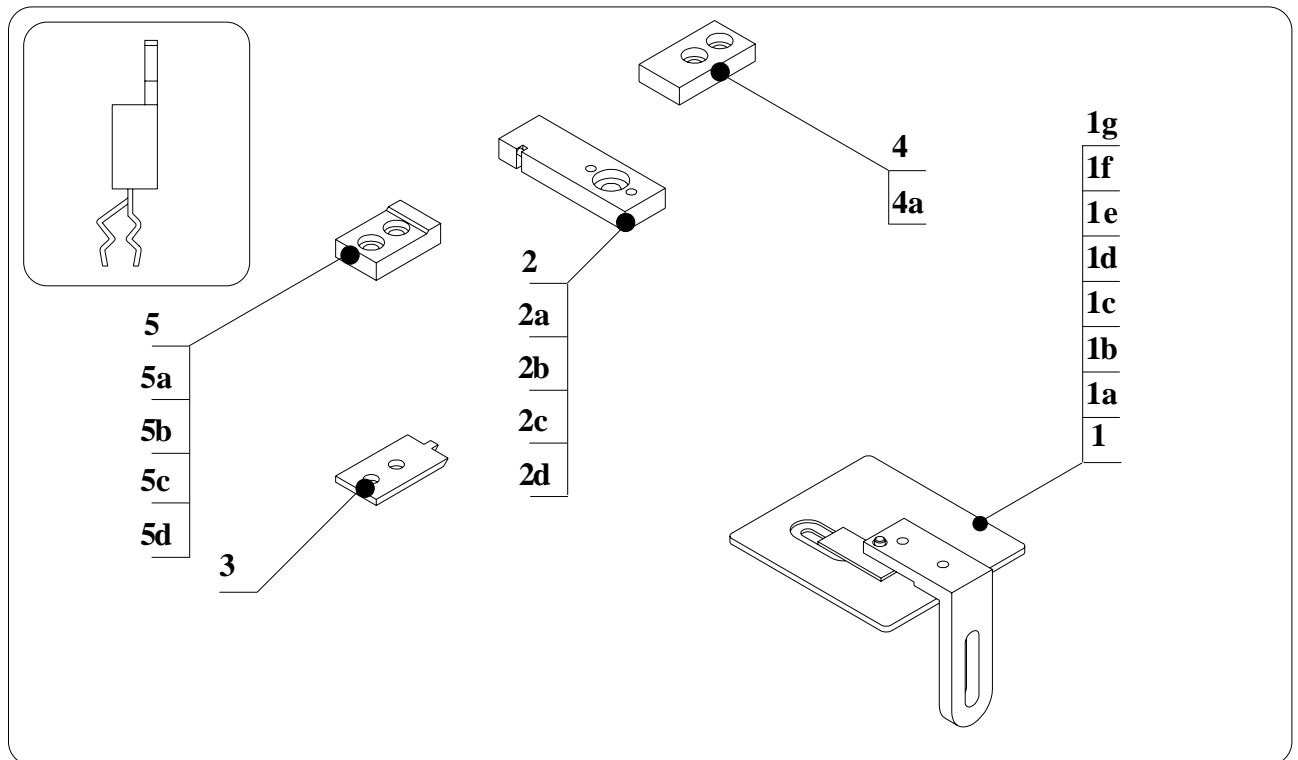

11.3.16.1 DETAILED SPARE PARTS LIST OF PREFORMING UNIT COD. 182300

Ref.	Item	Description	Q.ty
1	180048	ADJUSTER/REFERENCE + POSITION. CENTRE LEAD SPREAD-DOUBLE KINK ON 3 LEADS	1
1a	160026	PREFORMING REFERENCE/CENTRE LEAD OFF SET DOUBLE KINK ON 3 LEADS	1
1b	160031	PLATE	1
1c	850415	SCREW PP M3X4	1
1d	160025	PREFORMING REFERENCE FOR TO220	1
1e	160047	SCREW TS M3x10	2
1d	400116	NUT M3	1
1g	780517	KNOB FC-M3	1
2	162301	COMPLETE DIE TO220 CENTER LEAD SPREAD & 3 LEAD LOCK	1
2a	550012	BH SCREW M5X15	1
2b	163005	CAPSCREW M2x10	1
2c	162111	SMALL BLOCK FOR DIE TO220	1
3	162305	LEFT CUTTING BLADE TO220 CENT.LEAD SPREAD & 3 LEAD LOCK	1
4	161403	RIGHT FORMING PUNCH	1
4a	150210	REDUCED CAPSCREW M4X10	2
5	162303	COMPLETE LEFT FORMING PUNCH TO220 CENT.LEAD SPREAD & 3 LEAD LOCK	1
5a	150210	REDUCED CAPSCREW M4X10	2
5b	163005	CAPSCREW M2x10	1
5c	162304	INSERT FOR PUNCH TO220 CENTER LEAD SPREAD & 3 LEAD LOCK	1

11.3.17. DETAILED DRAWING OF PREFORMING UNIT COD.182400
TO 220 stand off/lock in 3 leads in line

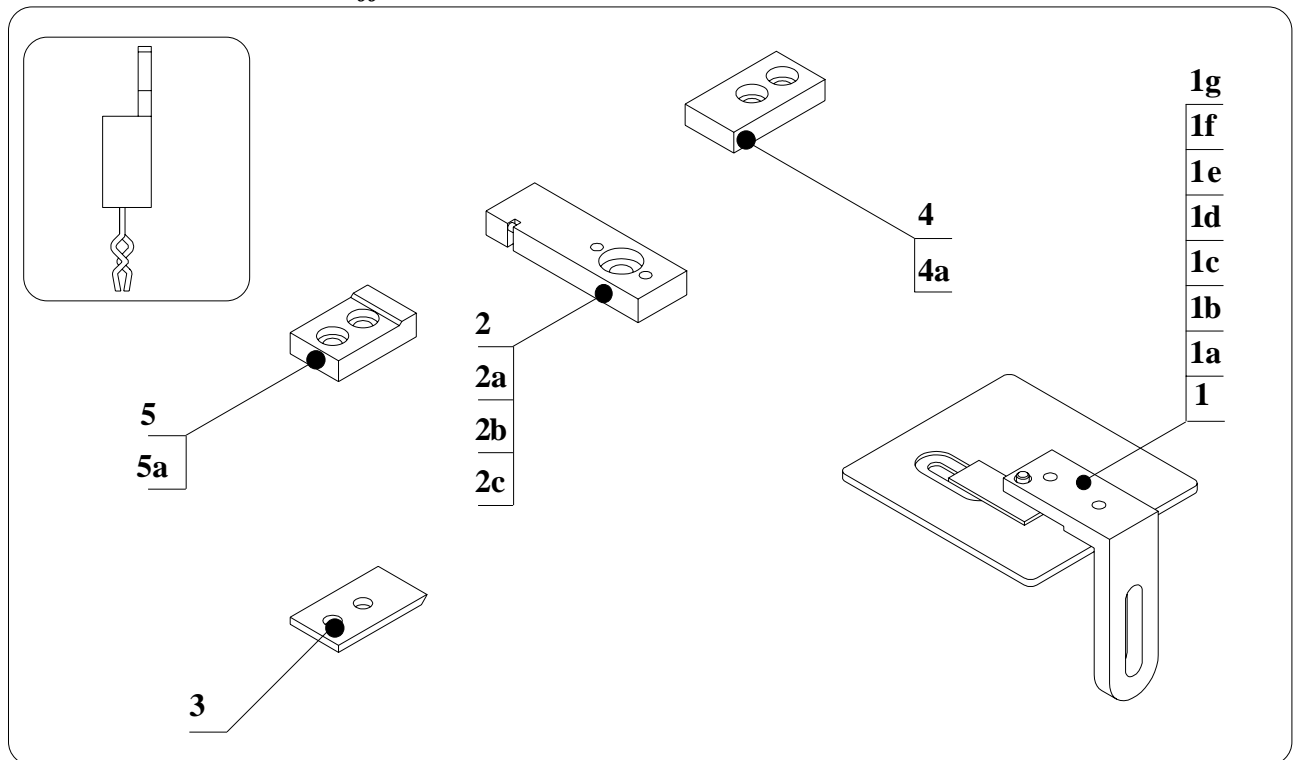

11.3.19.1 DETAILED SPARE PARTS LIST OF PREFORMING UNIT COD. 182400

Ref.	Item	Description	Q.ty
1	180042	COMPLETE HEIGHT ADJUSTER FOR COMP. TO220	1
1a	160024	HEIGHT ADJUSTER HOLDER FOR TO220 AND 90° BENDING CENT. LEAD SPREAD	1
1b	160031	PLATE	1
1c	850415	SCREW PP M3X4	1
1d	160025	PREFORMING REFERENCE FOR TO220	1
1e	160047	SCREW TS M3x10	2
1f	400116	NUT M3	1
1g	780517	KNOB FC-M3	1
2	162401	COMPLETE DIE TO220 STAND OFF LOCK IN 3 LEAD IN LINE	1
2a	162402	DIE STAND OFF LOCK IN 3 LEAD	1
2b	152402	INSERT FOR DIE TO220 STAND OFF LOCK IN	1
2c	163005	CAPSCREW M2x10	1
2d	750302	BH SCREW M5X12	1
3	160607	CUTTING BLADE TP/SC4	1
4	161403	RIGHT FORMING PUNCH	1
4a	150210	REDUCED CAPSCREW M4X10	2
5	162403	COMPLETE LEFT FORMING PUNCH TO220 STAND OFF LOCK IN 3 LEAD IN LINE	1
5a	162404	PUNCH STAND OFF LOCK IN 2 LEAD	1
5b	152404	INSERT FOR PUNCH TO220 STAND OFF LOCK IN 3 LEAD IN LINE	1
5c	163005	CAPSCREW M2x10	1
5d	150210	REDUCED CAPSCREW M4X10	2

11.3.18. DETAILED DRAWING OF PREFORMING UNIT COD. 182500
TO 92 center lead spread and cut

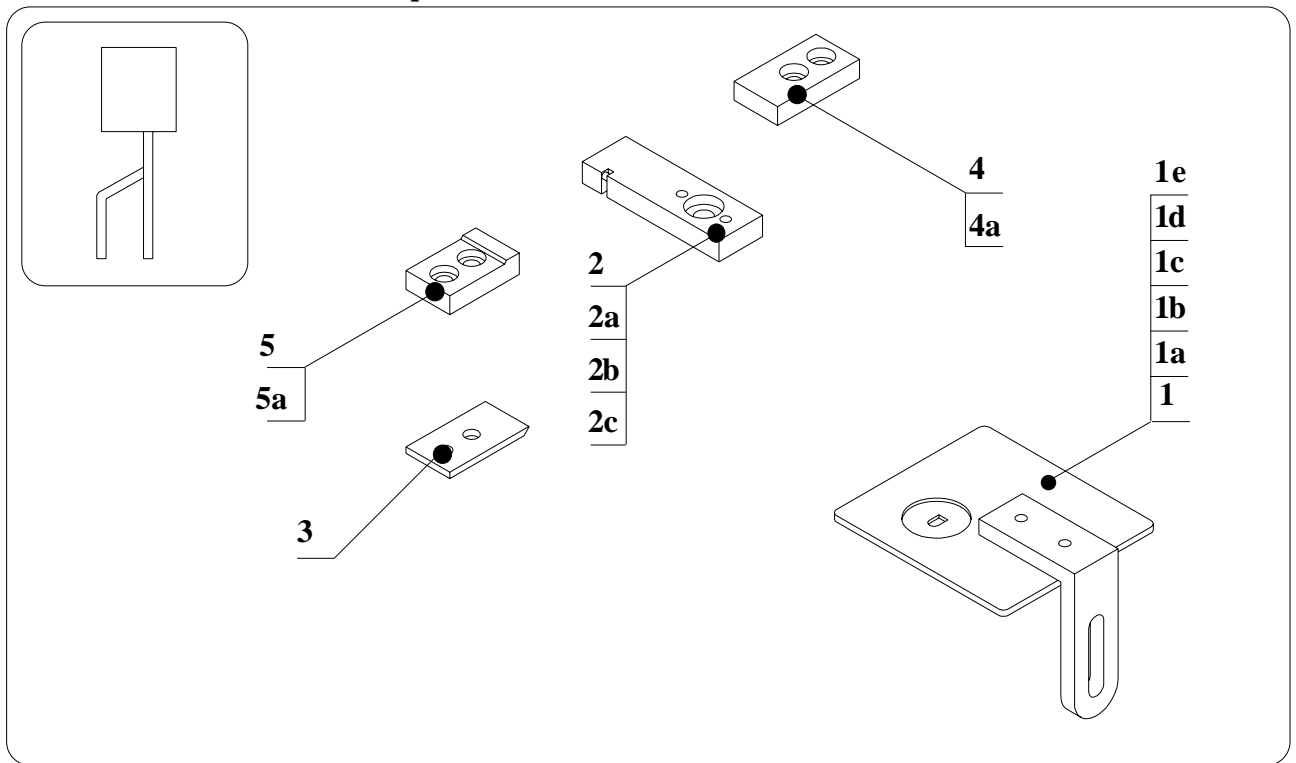

11.3.18.1 DETAILED SPARE PARTS LIST OF PREFORMING UNIT COD. 182500

Ref.	Item	Description	Q.ty
1	180044	<u>COMPLETE PREFORMING ADJUSTER TO92</u>	1
1a	160021	REFERENCE HOLDER FOR SMD / 90° BENDING/ TO220	1
1b	160029	PREFORMING REFERENCE TO92	1
1c	160047	SCREW TS M3x10	2
1d	400116	NUT M3	1
1e	780517	KNOB FC-M3	1
2	162501	<u>COMPLETE DIE TO92 CENTER LEAD SPREAD ON & CUT</u>	1
2a	162504	DIE TO92 CENTER LEAD SPREAD	1
2b	152110	CYLINDRIC PIN D. 2x10	1
2c	750302	BH SCREW M5X12	1
3	160607	CUTTING BLADE TP/SC4	1
4	161403	RIGHT FORMING PUNCH	1
4a	150210	RIGHT FORMING PUNCH	2
5	162502	LEFT FORMIGN PUNCH TO92 CENTER LEAD SPREAD ON & CUT	1
5a	150210	REDUCED CAPSCREW M4X10	2

11.3.19. DETAILED DRAWING OF PREFORMING UNIT COD. 182600
TO 92 center lead spread and lock

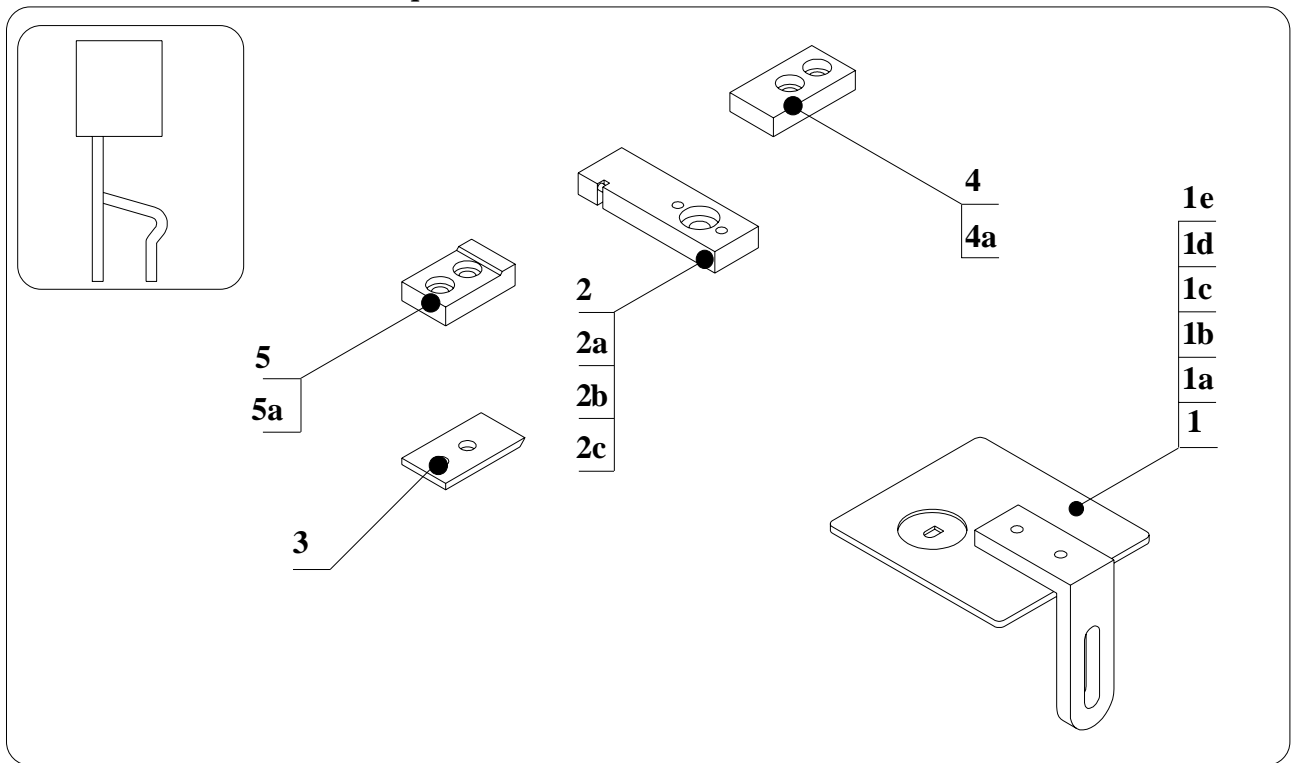

11.3.19.1 DETAILED SPARE PARTS LIST OF PREFORMING UNIT COD. 182600

Ref.	Item	Description	Q.ty
1	180044	COMPLETE PREFORMING ADJUSTER TO92	1
1a	160021	REFERENCE HOLDER FOR SMD / 90° BENDING/ TO220	1
1b	160029	PREFORMING REFERENCE TO92	1
1c	160047	SCREW TS M3x10	2
1d	400116	NUT M3	1
1e	780517	KNOB FC-M3	1
2	162601	COMPLETE DIE TO92 CENTER LEAD SPREAD & LOCK	1
2a	162603	DIE TO92 CENTER LEAD SPREAD & LOCK	1
2b	152110	CYLINDRIC PIN D. 2x10	1
2c	750302	BH SCREW M5X12	1
3	160607	CUTTING BLADE TP/SC4	1
4	161403	RIGHT FORMING PUNCH	1
4a	150210	REDUCED CAPSCREW M4X10	2
5	162602	LEFT FORMING PUNCH TO92 CENTER LEAD SPREAD & LOCK	1
5a	150210	REDUCED CAPSCREW M4X10	2

11.3.20. DETAILED DRAWING OF PREFORMING UNIT COD. 182700
TO 92 center lead spread & 3 leads lock

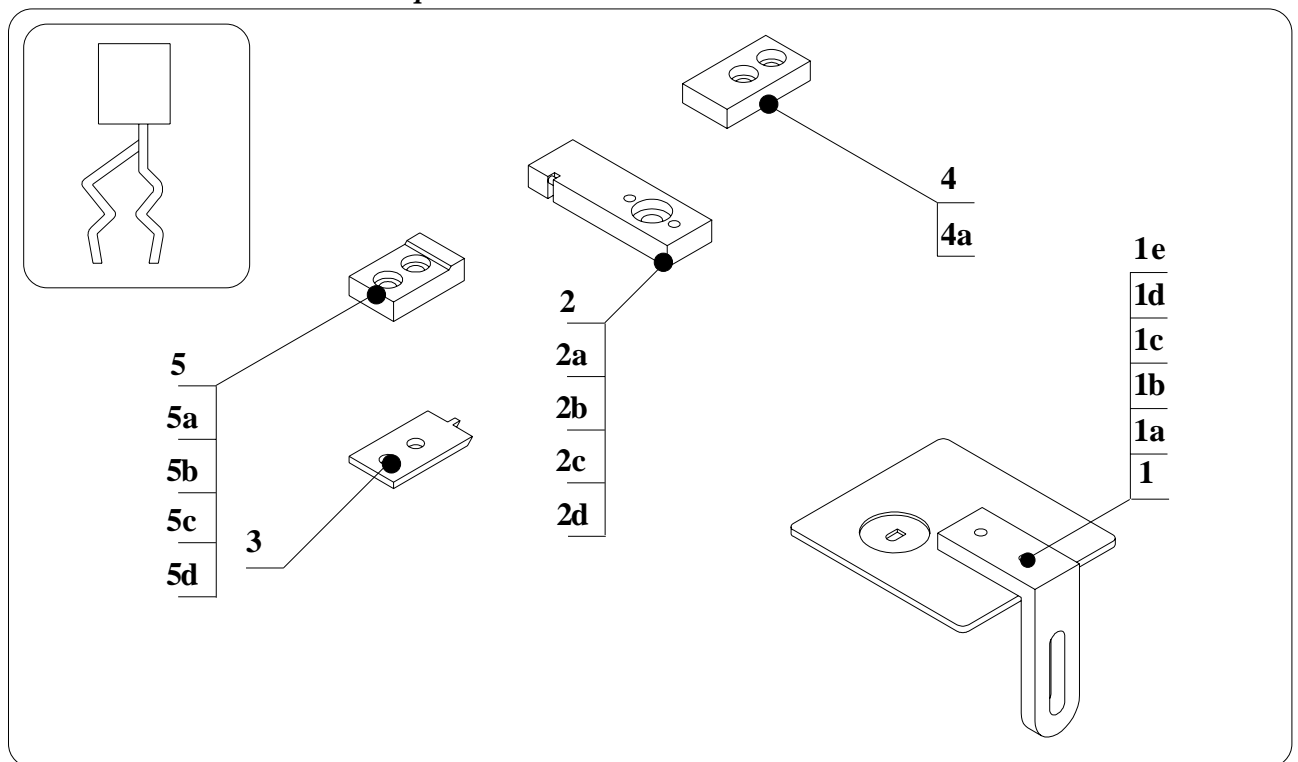

11.3.20.1 DETAILED SPARE PARTS LIST OF PREFORMING UNIT COD. 182700

Ref.	Item	Description	Q.ty
1	160044	COMPLETE PREFORMING ADJUSTER TO92	1
1a	160021	REFERENCE HOLDER FOR SMD / 90° BENDING/ TO220	1
1b	160029	PREFORMING REFERENCE TO92	1
1c	160047	SCREW TS M3x10	2
1d	400116	NUT M3	1
1e	780517	KNOB FC-M3	1
2	162701	COMPLETE DIE TO92 CENTER LEAD SPREAD & 3 LEAD LOCK	1
2a	162702	DIE TO92 STAND OFF LOCK IN 2 LEAD	1
2b	152702	INSERT FOR DIE TO92 CENTRE LEAD SPREAD DOUBLE KINK ON 3 LEADS	1
2c	163005	CAPSCREW M2x10	1
2d	750302	BH SCREW M5X12	1
3	162705	LEFT CUTTING BLADE TO92 CENTER LEAD SPREAD & 3 LEAD LOCK	1
4	161403	RIGHT FORMING PUNCH	1
4a	150210	REDUCED CAPSCREW M4X10	2
5	162703	COMPLETE LEFT FORMING PUNCH TO92 CENTER LEAD SPREAD & 3 LEAD LOCK	1
5a	162706	PUNCH TO92 STAND OFF LOCK IN 2 LEAD	1
5b	162704	INSERT FOR PUNCH TO92	1
5c	163005	CAPSCREW M2x10	1
5c	150210	REDUCED CAPSCREW M4X10	2

11.3.21. DETAILED DRAWING OF PREFORMING UNIT COD. 182800
TO 92 stand off/lock in 3 leads in line

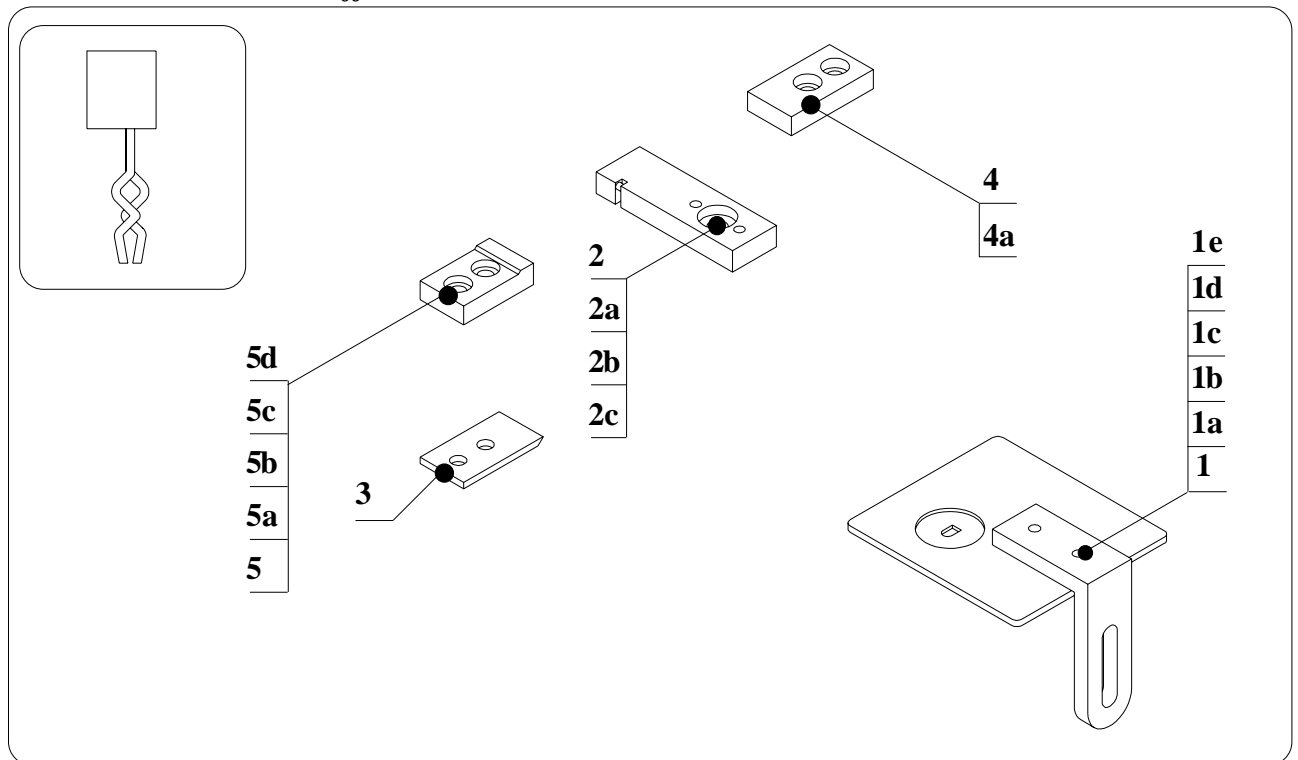

11.3.21.1 DETAILED SPARE PARTS LIST OF PREFORMING UNIT COD. 182800

Ref.	Item	Description	Q.ty
1	180044	COMPLETE PREFORMING ADJUSTER TO92	1
1a	160021	REFERENCE HOLDER FOR SMD / 90° BENDING/ TO220	1
1b	160029	PREFORMING REFERENCE TO92	1
1c	160047	SCREW TS M3x10	2
1d	400116	NUT M3	1
1e	780517	KNOB FC-M3	1
2	162801	COMPLETE DIE TO92 STAND OFF LOCK IN 3 LEAD IN LINE	1
2a	162802	DIE TO92 STAND OFF LOCK IN	1
2b	152802	INSERT FOR DIE TO92	1
2c	163005	CAPSCREW M2x10	1
2d	750302	BH SCREW M5X12	1
3	160607	CUTTING BLADE TP/SC4	1
4	161403	RIGHT FORMING PUNCH	1
4a	150210	REDUCED CAPSCREW M4X10	2
5	162803	COMPLETE LEFT FORMING PUNCH TO92 STAND OFF LOCK IN 3 LEAD IN LINE	1
5a	162804	LEFT PUNCH TO92 STAND OFF LOCK IN	1
5b	152804	INSERT FOR PUNCH TO92	1
5c	163005	CAPSCREW M2x10	1
5c	150210	REDUCED CAPSCREW M4X10	2